

# PyroUSB Series

## Operator's Guide



PyroUSB Series infrared sensors measure the temperature of surfaces without contact. They have a linear 2-wire 4 to 20 mA output, which is compatible with almost any indicator, controller, recorder or data logger without the need for special interfacing or signal conditioning.

A choice of measurement wavelengths and temperature ranges is available to suit a range of applications.

General-purpose PUA8 (8-14  $\mu\text{m}$ ) models can measure from  $-40^{\circ}\text{C}$  to  $1000^{\circ}\text{C}$ . They are suitable for measuring high-emissivity materials such as paper, thick plastics, food, pharmaceuticals, rubber, asphalt and painted surfaces.

Short-wavelength PUA2 (2.2  $\mu\text{m}$ ) models have a choice of temperature ranges from  $45^{\circ}\text{C}$  to  $2000^{\circ}\text{C}$ . They provide a more accurate reading when measuring low-emissivity materials such as many reflective metals. They are also capable of measuring through glass viewports.

Glass PUA5 (5  $\mu\text{m}$ ) models can measure from  $200^{\circ}\text{C}$  to  $1650^{\circ}\text{C}$ . They are filtered at a wavelength where glass is least reflective, making them ideal pyrometers for glass surface temperature measurement.

## SPECIFICATIONS

Model	PUA2	PUA5	PUA8
<b>Spectral Response</b>	2.0 to 2.6 $\mu\text{m}$ (2.2 $\mu\text{m}$ nominal)	5 $\mu\text{m}$	8 to 14 $\mu\text{m}$
<b>Application</b>	Ferrous metals and high-temperature targets	Glass	General purpose
<b>Temperature range</b>	Choice of ranges from $45^{\circ}\text{C}$ to $2000^{\circ}\text{C}$	Choice of ranges from $50^{\circ}\text{C}$ to $1650^{\circ}\text{C}$	$-40^{\circ}\text{C}$ to $1000^{\circ}\text{C}$
<b>Response time</b>	200 ms		
<b>Output</b>	2-wire, 4-20 mA, linear with measured temperature		
<b>Communications</b>	USB 2.0 (removable USB cable and software included) using the Modbus protocol		
<b>Optics</b>	Choice of optics for small or large targets at short or long distances (see Optics)		
<b>Accuracy</b>	$\pm 2^{\circ}\text{C}$ or 1% of reading, whichever is greater	$\pm 1^{\circ}\text{C}$ or 1% of reading, whichever is greater	
<b>Repeatability</b>	$\pm 0.5^{\circ}\text{C}$ or 0.5% of reading, whichever is greater		
<b>Emissivity Setting</b>	0.1 to 1.0		
<b>Maximum Span (4-20 mA output)</b>	Full temperature range		
<b>Minimum Span (4-20 mA output)</b>	100 $^{\circ}\text{C}$		

ELECTRICAL	
Supply Voltage	24 V DC (28 V DC max)
Sensor Voltage (minimum)	6 V DC
Maximum Loop Impedance	900 $\Omega$ @ 24 V DC

## MECHANICAL

Construction	Stainless Steel
Dimensions	Ø 27.6 x length 61 mm including cable glands
Thread mounting	M20 x 1 mm pitch, length 15 mm
4-20 mA Output Cable Length	1 m (standard), up to 30 m (optional)
Weight with 1 m Output Cable	155 g
USB Cable Length	1.8 m

## ENVIRONMENTAL

Environmental Rating	IP65
Ambient (Operating) Temperature	0°C to 70°C (cooled models are available for higher temperatures)
Relative Humidity	95% max. non-condensing

### MINIMUM MEASURABLE TEMPERATURE (PUA2-151-LT ONLY)

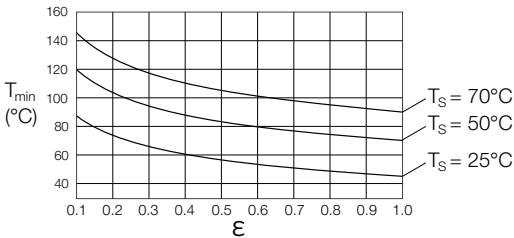

Graph showing the minimum measurable object temperature ( $T_{min}$ ), determined by surface emissivity ( $\epsilon$ ) and sensor temperature ( $T_S$ ).

## DIMENSIONS

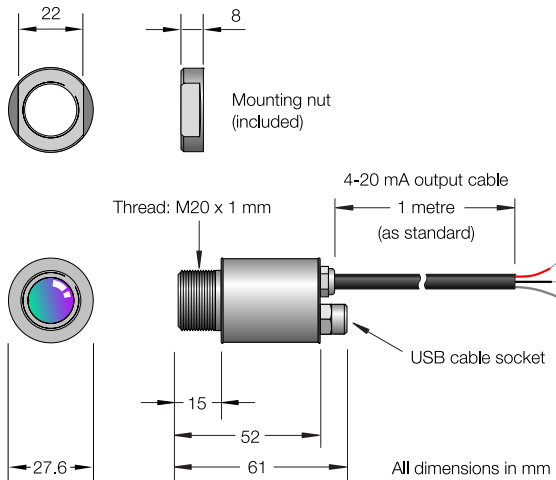

## MODEL NUMBERS

Short Wavelength    PUA2 - 251 - MT - WJ

Glass    PUA5 - 251 - GHT - WJ

General Purpose    PUA8 - 301 - - WJ

**Cooling**  
**(blank)** Sensor without cooling  
**WJ** Air/water cooled jacket with air purge collar

### Temperature range

#### PUA2

**LT** 45°C to 300°C  
 (151 models only)

**PT** 100°C to 400°C  
 (151 models only)

**MT** 250°C to 1000°C

**HT** 450°C to 2000°C

#### PUA5

**GLT** 50°C to 1000°C

**GHT** 200°C to 1650°C

#### PUA8

**(blank)** All models:  
 -40°C to 1000°C

### Field of view

#### PUA2

**151** 15:1 divergent optics (LT & PT models only)

**251** 25:1 divergent optics

**751** 75:1 divergent optics

#### PUA5

**251** 25:1 divergent optics

#### PUA8

**301** 30:1 divergent optics

**CF** Close-focus optics (focal spot size  
 5 mm at 100mm distance)

### Spectral response

**PUA2** 2.2  $\mu\text{m}$ , for measuring reflective metals and high-temperature objects

**PUA5** 5  $\mu\text{m}$ , for measuring glass surface temperature

**PUA8** 8 to 14  $\mu\text{m}$ , general-purpose, for non-reflective non-metals, painted metal surfaces and most other applications

## ACCESSORIES

A range of accessories to suit different applications and industrial environments is available. These may be ordered at any time and added on-site:

- Fixed and adjustable mounting brackets
- Air purge collar
- Laser sighting tool
- Mounting bracket with continuous laser sighting

## OPTIONS

The following options are available. Options are factory installed and must be ordered with the sensor.

- Air/water cooled housing
- Certificate of calibration
- Longer cable (30 m max.)

## OPTICS

These diagrams show the nominal target spot diameter at any given distance from the sensing head and assumes 90% energy. It is possible to measure at longer distances than the diagrams show, with a larger measured spot size. There is no maximum measurement distance in clear air.

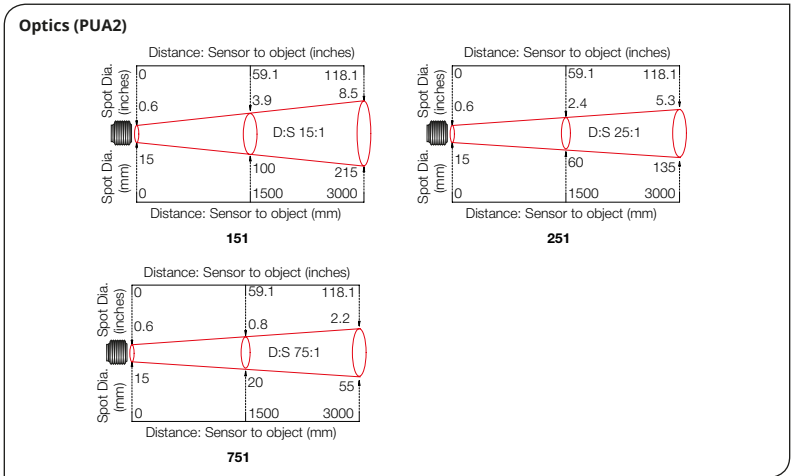
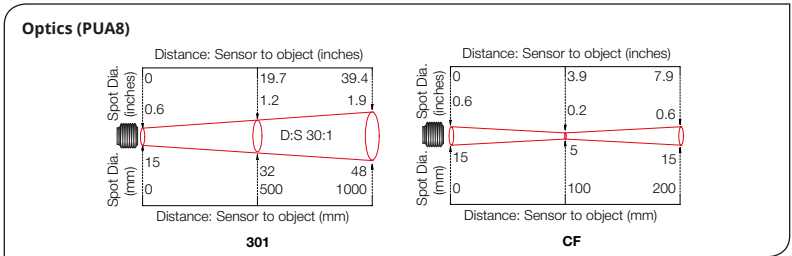
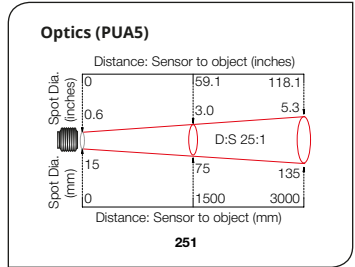

## INSTALLATION

The installation process consists of the following stages:

- 1 Preparation
- 2 Mechanical installation
- 3 Electrical installation

Please read the following sections thoroughly before proceeding with the installation.

## PREPARATION

Ensure that the sensor is positioned so that it is focused on the target only.

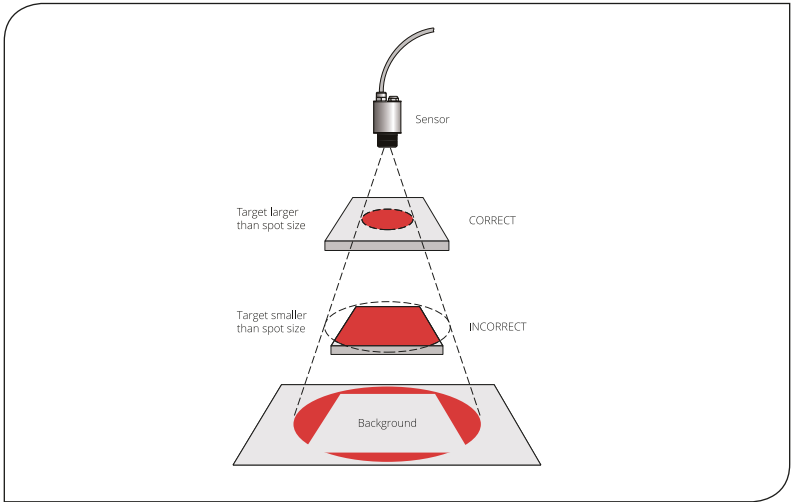

## DISTANCE AND SPOT SIZE

The size of the area (spot size) to be measured determines the distance between the sensor and the target. The spot size must not be larger than the target. The sensor should be mounted so that the measured spot size is smaller than the target.

## REFLECTIONS

The sensor must be installed in a location where energy from lamps, heaters and sunlight cannot be reflected from the target into the lens. The use of shields may help in this respect. For further information and assistance contact Calnex.

## AMBIENT TEMPERATURE

The sensor is designed to operate in ambient temperatures from 0°C to 70°C. For ambient temperatures above 70°C, an air/water-cooled housing will be required. Avoid thermal shock. Allow 20 minutes for the unit to adjust to large changes in ambient temperature.

## ATMOSPHERIC QUALITY

Smoke, fumes or dust can contaminate the lens and cause errors in temperature measurement. In these types of environment the air purge collar should be used to help keep the lens clean.

## ELECTRICAL INTERFERENCE

To minimise electromagnetic interference or 'noise', the sensor should be mounted away from motors, generators and such like.

## WIRING

Check the distance between the sensor and the indicating/controlling device. If necessary, the sensor can be ordered with a longer cable attached.

## POWER SUPPLY

Be sure to use a 24 V DC (22 mA) power supply.

## MECHANICAL INSTALLATION

All sensors come with a 1m cable and a mounting nut. The sensor can be mounted on brackets or cut outs of your own design, or you can use the fixed and adjustable mounting bracket accessories which are shown below.

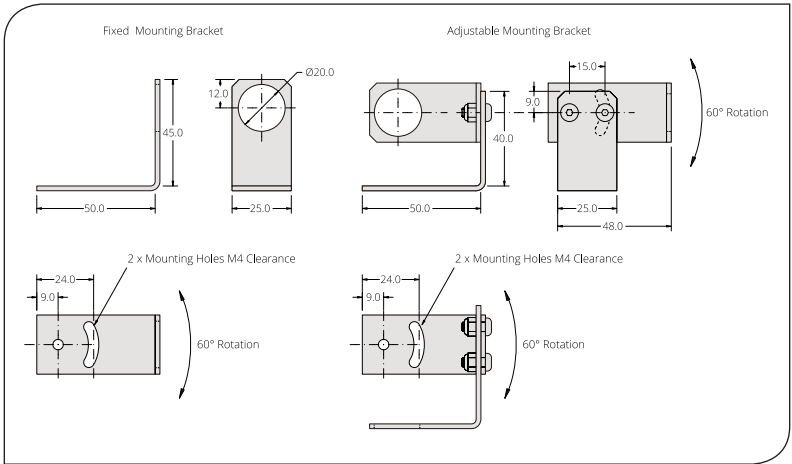

## AIR/WATER COOLED HOUSING

The air/water cooled housing shown below allows the sensor to withstand high ambient temperatures. It is equipped with two 1/8" BSP fittings. Water temperature should be 10°C to 27°C for efficient cooling. Chilled water below 10°C is not recommended. To avoid condensation, the air purge collar should be used with the water-cooled housing. Water flow rate should be 0.5 to 1.5 litres/min. Adjust the flow rate and temperature of the cooling fluid to keep the sensor body between 0°C and 70°C.

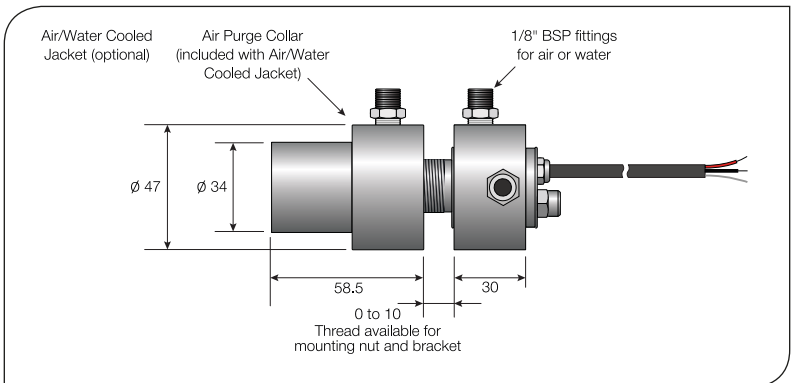

## AIR PURGE COLLAR

The air purge collar below is used to keep dust, fumes, moisture, and other contaminants away from the lens. It must be screwed in fully. Air flows into the 1/8" BSP fitting and out of the front aperture. Air flow should be 5 to 15 litres/min.

Clean or 'instrument' air is recommended.

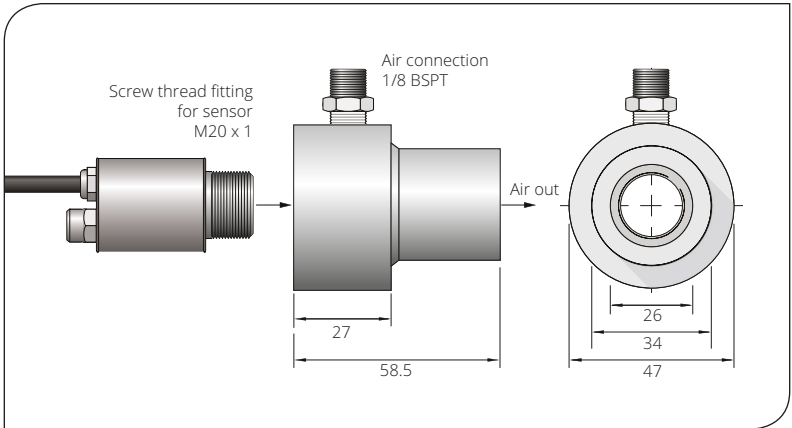

## ELECTRICAL INSTALLATION

The 4-20 mA output cable is 1 m long as standard. The outer jacket is PVC. One end is attached, at the factory, to the sensor head. The other end has a pair of wires and a shield (ground) wire.

## WIRING

The sensor can be used in 3 different ways as shown below. To use the 4-20 mA output, connect the sensor to the controller/indicator with the 24 V DC power supply in the loop using the following table and connection diagram as a guide. The maximum loop impedance is 900 ohms.

**Note: The sensor must be grounded at only one point, either the cable shield or the sensor housing.**

Output	Wire No.	Wire Colour	Function
4 to 20 mA	1	Red	Power supply + / signal +
	2	Black	Power supply - / signal -
-	3	Bare	Shield ground

Alternatively, to use the USB output, connect the sensor to a PC using the cable provided. No external power supply is required when using the USB output. The sensor can also be used with both the 4-20 mA loop and USB connected, provided that the negative terminal of the 24 V DC power supply being used is not grounded.

**IMPORTANT: The sensor will work only with the supplied USB cable. Connecting any other type of USB cable may damage the sensor and invalidate the warranty.**

Note: The software must be installed before connecting the sensor to a PC.



## CONNECTIONS

The sensor will operate with either the 4 to 20 mA cable connected, the USB cable connected, or both.

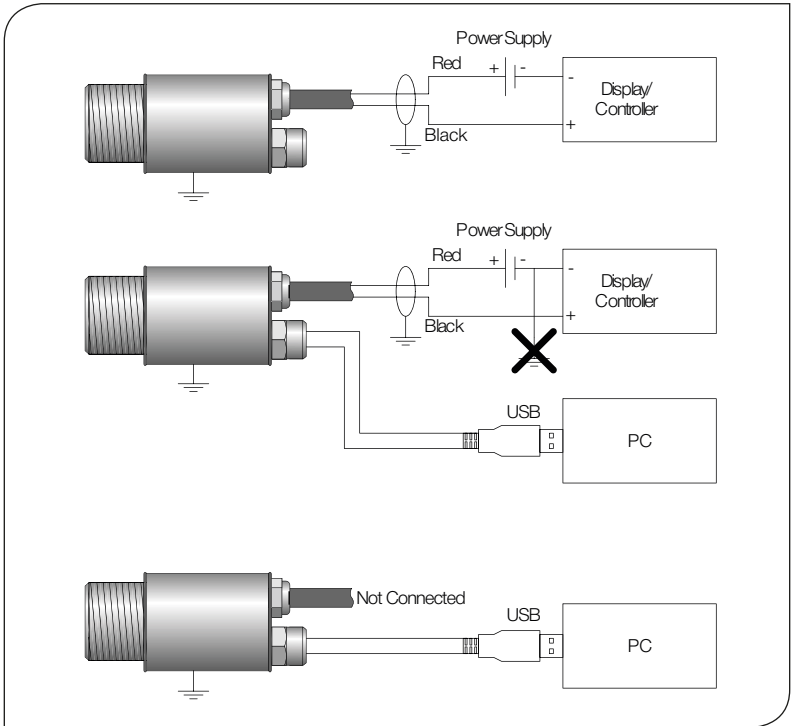

## SOFTWARE

The sensor may be used with a choice of software: CalexConfig (for one sensor), CalexSoft 2 (for multiple sensors), or third-party Modbus software.

### System Requirements

- Windows 7 or newer
- USB 2.0 port, Internet access (for software download)

### Installation

- 1 Download and run the software installer at [www.calex.co.uk/software](http://www.calex.co.uk/software)
- 2 Follow the on-screen instructions

**NOTE: Do not use any other USB cable than the one supplied with the sensor. Do not connect the sensor to the PC before the software is installed.**

### CONNECTING THE SENSOR TO A PC

- 1 Connect the circular connector on the USB cable provided to the sensor
- 2 Connect the USB A connector on the USB cable provided to an available USB 2.0 port
- 3 Double click on the software desktop icon

## CONFIGURATION (VIA CALEXCONFIG SOFTWARE)

Configuration settings are password protected. To access the Settings menu, go to the Unlock screen and enter the password. **The default password is 1234.**

### Temperature Units

On the temperature display screen, click °C or °F to switch between temperature units.

### Output Processing

Go to the Settings screen, then Output Processing.

#### 4 to 20 mA output scale

Set the temperature range limits for the 4 to 20 mA output. The temperature limits depend on the sensor model (see Model Numbers). Ensure the temperature range on the measurement instrument matches the 4-20 mA output scale.

Default setting: Full temperature range (depending on model).

The difference between the temperatures at 4 mA and at 20 mA must be at least 100°C. The temperature at 20 mA must be greater than the temperature at 4 mA.

#### Averaging period

Set the time, in seconds, over which the measured temperature is averaged. Note: averaging prevents the sensor from following rapid temperature changes.

Default setting: 0.

#### Peak/valley hold processing

If required, hold processing can be applied by setting Hold Mode to "Peak" or "Valley" and setting the hold period. This is useful if the temperature reading is interrupted by gaps between moving objects, or by an obstruction.

Default settings: Hold Mode: Off  
Hold Period: 0

### Emissivity and Compensation

From the Settings menu, go to Emissivity and Compensation.

#### Emissivity Setting

Enter the emissivity of the target. Target emissivity can be determined experimentally, or estimated using an emissivity table. For more information, contact Calex.

Default setting: 0.95

#### Window Transmissivity

When aiming the sensor through an IR-transmissive window, this setting should be adjusted to compensate for the presence of the window. Enter the transmissivity of the window (Enter "1" if no window is present).

Default Setting: 1

#### Reflected Energy Compensation On/Off

If enabled, compensates for errors caused by reflected energy from hotter or colder objects.

Default setting: Off

#### Reflected Temperature

Enter the temperature of the surroundings of the target for Reflected Energy Compensation.

Changing this setting has no effect when Reflected Energy Compensation is Off.

# MODBUS OVER SERIAL LINE

## Interface

Baud rate 9600  
Format (bits) 8 data, No parity, 1 stop  
Reply delay 20 ms

## Supported Functions

Read register 0x03, 0x04  
Write single register 0x06  
Write multiple register 0x10

## List of Modbus Addresses

The list below includes all available addresses:

R = Read, W = Write

Address	Length (words)	Description	R/W
0x00	1	Sensor Type 21 = PUA8, 22 = PUA2, 23 = PUA5	R
0x01	1	Field of view: PUA8: 0 = 30:1, 1 = CF PUA2: 0 = 15:1, 1=25:1, 2 = 75:1 PUA5: 0 = 25:1	R
0x02	2	Serial number	R
0x04	1	Temperature range (PUA2 only):0 = LT, 1 = PT, 2 = MT, 3 = HT	R
0x05	1	Modbus slave address	R/W
0x06	1	Reflected Energy Compensation 0 = Off, 1 = On	R/W
0x07	1	Reflected Temperature	R/W
0x08	1	Emissivity (1 LSB = 0.0001) Minimum 0.1000, Maximum 1.0000	R/W
0x09	1	Window Transmissivity (1 LSB = 0.0001) Minimum 0.2000, Maximum 1.0000 For when using the sensor with an IR window	R/W
0x0A	1	Output Scale: Temperature at 4 mA	R/W
0x0B	1	Output Scale: Temperature at 20 mA	R/W
0x0C	1	Hold Mode 0 = Off, 1 = Peak, 2 = Valley	R/W
0x0D	1	Hold Period (1 LSB = 0.1 seconds) Minimum 0, maximum 1200.0 s	R/W
0x0E	1	Average Period (1 LSB = 0.1 seconds) Minimum 0, maximum 60.0 s	R/W
0x0F	1	Average Temperature	R
0x10	1	Minimum Temperature	R

Address	Length (words)	Description	R/W
0x11	1	Maximum Temperature	R
0x12	1	Filtered Temperature	R
0x13	1	Unfiltered Temperature	R
0x14	1	Sensor Temperature	R
0x15	1	Status (bits active high): Bit 0: Measurement error Bit 1: Sensor temperature low Bit 2: Sensor temperature high Bit 3: Object temperature low Bit 4: Object temperature high	R
0x17	1	Reflected Temperature Not saved to non-volatile memory Use this register when writing frequently	R/W
0x18	1	Emissivity (1 LSB = 0.0001) Minimum 0.1000, Maximum 1.0000 Not saved to non-volatile memory Use this register when writing frequently	R/W

**Notes:**

- 1 All temperature are in tenths of degrees C
- 2 With the exception of addresses 0x17 and 0x18, all write operations are saved to non-volatile memory
- 3 For further information please refer to <http://www.modbus.org/specs.php>
- 4 The default Modbus slave address of the sensor is 1; it is also possible to use slave address 255 to communicate. 1 sensor may be connected per COM port.

## DEFAULT SETTINGS

Modbus Slave Address	1
Emissivity Setting	0.95
Reflected Energy Compensation	Off
Window Transmissivity	1
4-20 mA Output Scale	Full temperature range, depending on model
Hold Mode	Off
Hold Period	0
Average Period	0

## OPERATION

Once the sensor is in position and the appropriate power, air, water, and cable connections are secure, the system is ready for continuous operation by completing the following simple steps:

- 1 Turn on the power supply (not required if connected by USB only)
- 2 Turn on the instrument or PC
- 3 Read / monitor the temperature

## IMPORTANT

**Be aware of the following when using the sensor:**

- If the sensor is exposed to significant changes in ambient temperature (hot to cold, or cold to hot), allow 20 minutes for the temperature to stabilise before taking or recording measurements.
- Do not operate the sensor near large electromagnetic fields (e.g. around arc welders or induction heaters).
- Electromagnetic interference can cause measurement errors.
- Wire must be connected only to the appropriate terminals.
- Do not open the sensor housing. This will damage the sensor and invalidate the warranty.

## MAINTENANCE

Our customer service representatives are available for application assistance, calibration, repair, and solutions to specific problems. Contact our Service Department before returning any equipment. In many cases, problems can be solved over the telephone.

If the sensor is not performing as it should, see TROUBLESHOOTING and try to match the symptom to the problem. If the table does not help, call Calnex for further advice.

## LENS CLEANING

Keep the lens clean at all times. Any foreign matter on the lens would affect measurement accuracy. Blow off loose particles (if not using the air purge accessory) with an air 'puffer'.

## TROUBLESHOOTING

Symptom	Probable Cause	Solution
No output	No power to sensor	Check power supply and wiring
Inaccurate measured temperature	Target too small for sensor's field of view	Ensure the sensor's view is completely filled by the target. Position the sensor closer to the target to measure a smaller area. Ensure the target is at least twice the size of the given measured spot
	Target is a reflective metal surface	All models: Measure a non-reflective area, or paint or coat a measurable area of the target to make it non-reflective. 2.2 µm models: When measuring reflective metals, try changing the emissivity setting
	Field of view obstruction	Remove obstruction; ensure sensor has a clear view of target
	Dust or condensation on lens	Ensure lens is clean and dry. Clean gently with a soft lens cloth and water. If problem recurs, consider using an air purge collar
	Incorrect wire connections	Check wire colour codes and tags - see WIRING
	Output temperature scale mismatch	Re-scale input temperature range on measurement instrument to match sensor. Use software to check output temperature range.

## GUARANTEE

Calex guarantees each instrument it manufactures to be free from defect in material and workmanship under normal use and service for the period of two years from the date of purchase. This guarantee extends only to the original buyer according to Calex Terms and Conditions of Sale.



**Calex Electronics Limited**

PO Box 2, Leighton Buzzard, Bedfordshire, England LU7 4AZ

Tel: +44 (0)1525 373178 | [mail@calex.co.uk](mailto:mail@calex.co.uk) | [www.calex.co.uk](http://www.calex.co.uk)